

Technical Data sheet - Motor Focquet



MF4B2B14IE3

GU

Squirrel cage asynchronous motor
Type of motor IEC 112M2 IE3

2 poles - frame 112M - 4kW - 400/690V - 50Hz - Cast Iron - IE3

ELECTRICAL DATA		
Rated motor voltage	V	400/690
Rated frequency	Hz	50
Rated motor power	kW	4
Rated motor speed	rpm	2910
Rated motor current	A	8/5
Starting/Rated current (Is/In)		8.3
Rated torque	Nm	13
Starting/Rated torque (Ts/Tn)		2.2
Breakdown/Rated torque (Tmax/Tn)		2.3
Efficiency at 100%	%	88.1
Power factor at 100%		0.88

MECHANICAL DATA		
Balancing		Half Key
Bearing DE		6306ZZ
Bearing NDE		6306ZZ
Lubricant type		N/A

GENERAL DATA		
Frame size	mm	112
Type of mounting		B14
Flange in B14	mm	110x130x160
Weight	kg	61
Degree of protection		IP55
Method of cooling		IC411
Material of housing		Cast Iron
Terminal box		See drawings / TOP
Insulation class - Temperature class		F/B 80K DOL F/F 105K in VSD S9 (35 - 50Hz)
Duty type		S1
Paint Ral n°		5003
Direction of rotation		Clockwise/Counterclockwise
Noise @ 1m	dB (A)	77
Inertia rotor	kgm ²	0.0063
Vibration class		Class B
Shaft diameter	mm	28

SITE CONDITIONS		
Ambient temperature	°C	-20 - +40°C
Altitude above sea level	m	0-1000m

NOTES - COMMENTS		
3 x PTC 150°C Windings		included

STANDARDS		
Specification: IEC 60034-1	Vibration: IEC 60034-14	
Tests: IEC 60034-2	Tolerance: IEC 60034-1	
Noise: IEC 60034-9		

The rating plate values can be different from the calculated values: Data subject to changes.

Focquet 2022

This document is exclusive property of FOCQUET SA. Reprinting is not allowed without written authorization.

Focquet
DEPUIS 1892 - SINDS 1892



ISO 9001 :2015
N° : 44.100.150657

Rue des Halpes 1
5030 Gembloux - Belgium
TEL +32 (0) 81 62 59 70

info@focquet.be
www.focquet.be

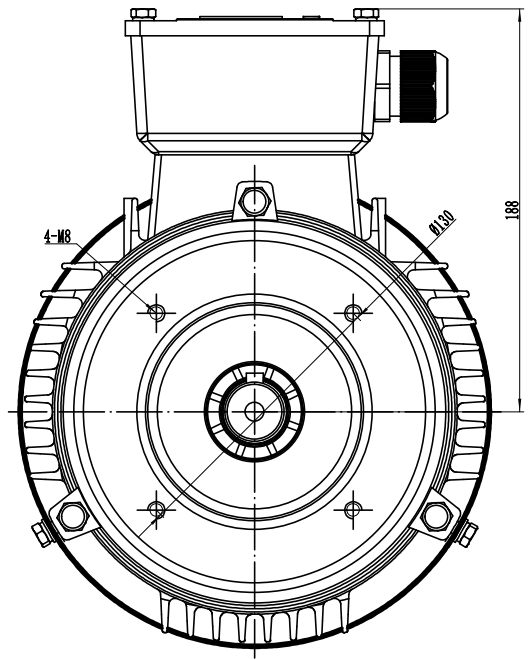
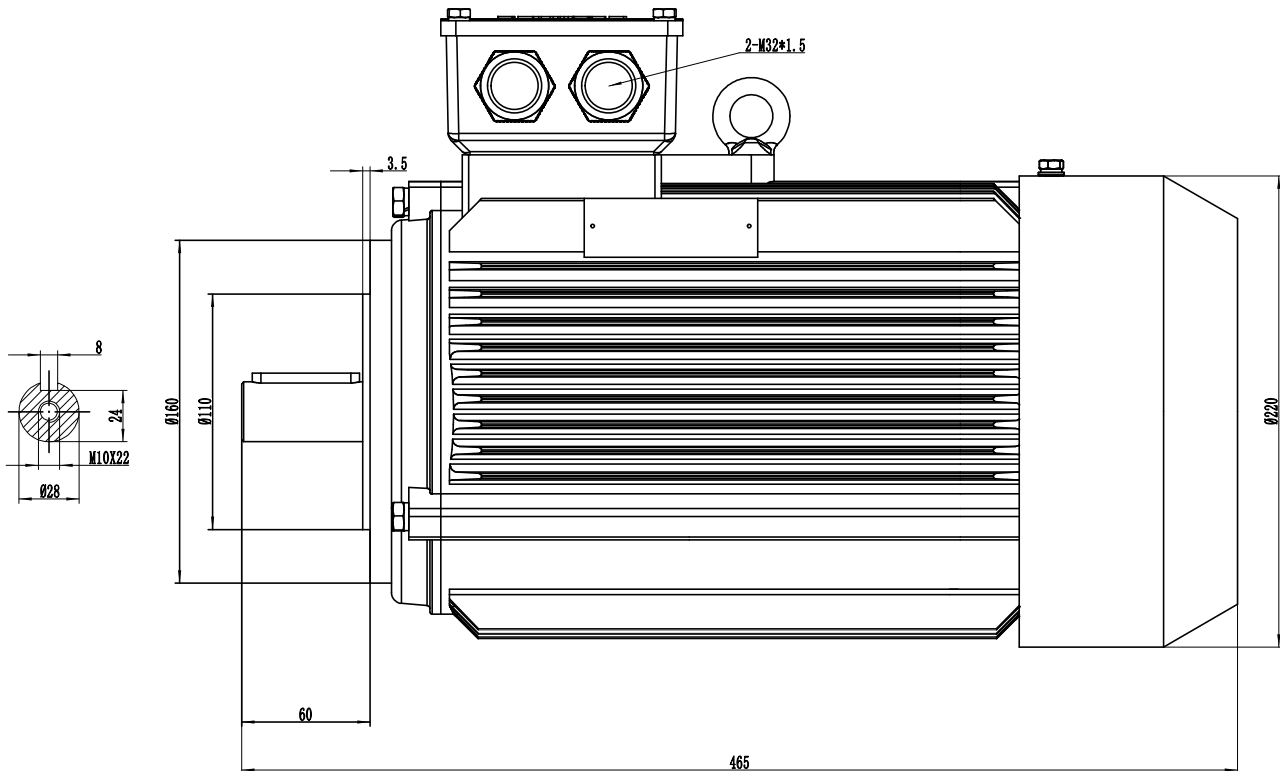

IE3-112M-B14