

Technical Data sheet - Motor Focquet



MF5B6B34IE4

GU

Squirrel cage asynchronous motor
Type of motor IEC 132M6 IE4

6 poles - frame 132M - 5.5kW - 400/690V - 50Hz - Cast Iron - IE4

ELECTRICAL DATA		
Rated motor voltage	V	400/690
Rated frequency	Hz	50
Rated motor power	kW	5.5
Rated motor speed	rpm	975
Rated motor current	A	13/8
Starting/Rated current (Is/In)		8.0
Rated torque	Nm	54
Starting/Rated torque (Ts/Tn)		2.0
Breakdown/Rated torque (Tmax/Tn)		2.1
Efficiency at 100%	%	90.5
Power factor at 100%		0.72

MECHANICAL DATA		
Balancing		Half Key
Bearing DE		6308ZZ
Bearing NDE		6308ZZ
Lubricant type		N/A

GENERAL DATA		
Frame size	mm	132
Type of mounting		B34
Flange in B34	mm	130x165x200
Weight	kg	83
Degree of protection		IP55
Method of cooling		IC411
Material of housing		Cast Iron
Terminal box		See drawings / TOP
Insulation class - Temperature class		F/B 80K DOL F/F 105K in VSD S9 (35 - 50Hz)
Duty type		S1
Paint Ral n°		5003
Direction of rotation		Clockwise/Counterclockwise
Noise @ 1m	dB (A)	69
Inertia rotor	kgm ²	0.0548
Vibration class		Class B
Shaft diameter	mm	38

SITE CONDITIONS		
Ambient temperature	°C	-20 - +40°C
Altitude above sea level	m	0-1000m

NOTES - COMMENTS		
3 x PTC 150°C Windings		included

STANDARDS		
Specification: IEC 60034-1	Vibration: IEC 60034-14	
Tests: IEC 60034-2	Tolerance: IEC 60034-1	
Noise: IEC 60034-9		

The rating plate values can be different from the calculated values: Data subject to changes.

Focquet 2022

This document is exclusive property of FOCQUET SA. Reprinting is not allowed without written authorization.

Focquet
DEPUIS 1892 - SINDS 1892



ISO 9001 :2015
N° : 44.100.150657

Rue des Halpes 1
5030 Gembloux - Belgium
TEL +32 (0) 81 62 59 70

info@focquet.be
www.focquet.be

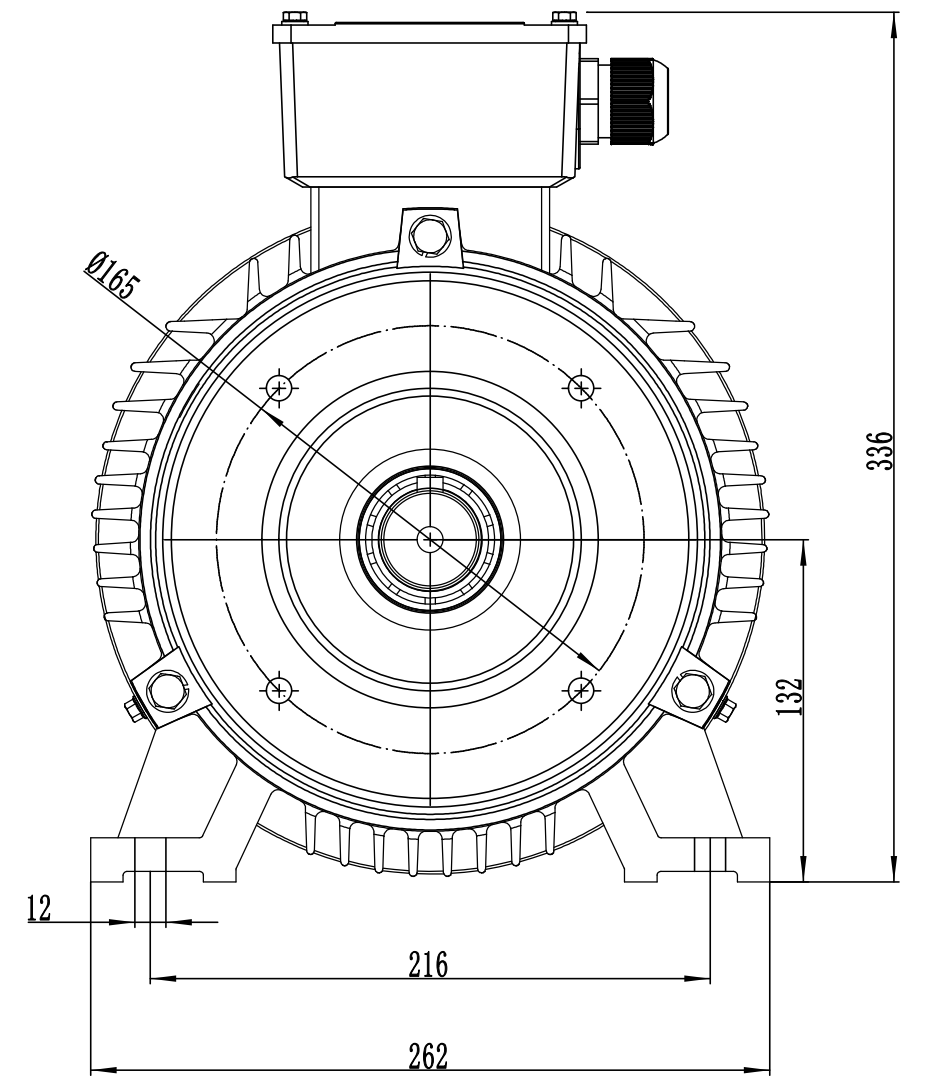
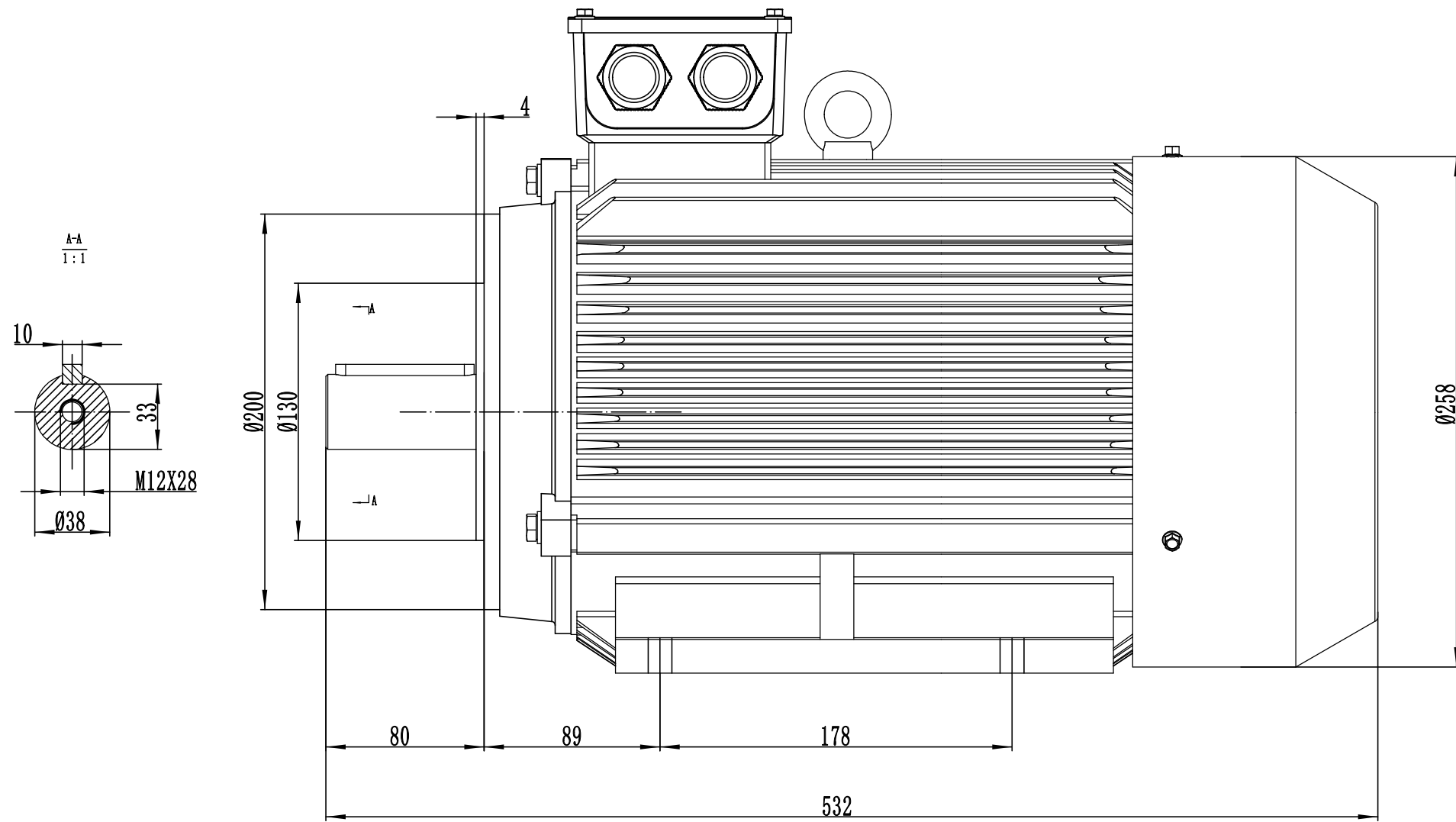

IE4-132M-B34