

## MF9B2B35IE3

GU

Squirrel cage asynchronous motor  
Type of motor IEC 132M-2 IE3

2 poles - frame 132M - 9.2kW - 400/690V - 50Hz - Cast Iron - IE3

### ELECTRICAL DATA

Rated motor voltage	V	400/690
Rated frequency	Hz	50
Rated motor power	kW	9.2
Rated motor speed	rpm	2940
Rated motor current	A	17/10
Starting/Rated current (Is/In)		9.5
Rated torque	Nm	30
Starting/Rated torque (Ts/Tn)		2.0
Breakdown/Rated torque (Tmax/Tn)		2.3
Efficiency at 100%	%	90.1
Power factor at 100%		0.89

### MECHANICAL DATA

Balancing		Half Key
Bearing DE		6308ZZ
Bearing NDE		6308ZZ
Lubricant type		N/A

### GENERAL DATA

Frame size	mm	132
Type of mounting		B35
Flange in B35	mm	230x265x300
Weight	kg	81
Degree of protection		IP55
Method of cooling		IC411
Material of housing		Cast Iron
Terminal box		See drawings / TOP
Insulation class - Temperature class		F/B 80K DOL F/F 105K in VSD S9 (35 - 50Hz)
Duty type		S1
Paint Ral n°		5003
Direction of rotation		Clockwise/Counterclockwise
Noise @ 1m	dB (A)	79
Inertia rotor	kgm <sup>2</sup>	0.0181
Vibration class		Class B
Shaft diameter	mm	38

### SITE CONDITIONS

Ambient temperature	°C	-20 - +40°C
Altitude above sea level	m	0-1000m

### NOTES - COMMENTS

3 x PTC 150°C Windings		included
------------------------	--	----------

### STANDARDS

Specification: IEC 60034-1	Vibration: IEC 60034-14
Tests: IEC 60034-2	Tolerance: IEC 60034-1
Noise: IEC 60034-9	

The rating plate values can be different from the calculated values: Data subject to changes.

Focquet 2022

This document is exclusive property of FOCQUET SA. Reprinting is not allowed without written authorization.

**Focquet**  
DEPUIS 1892 - SINDS 1892



ISO 9001 :2015  
N° : 44.100.150657

Rue des Haïpes 1  
5030 Gembloux - Belgium  
TEL +32 (0) 81 62 59 70

info@focquet.be  
www.focquet.be

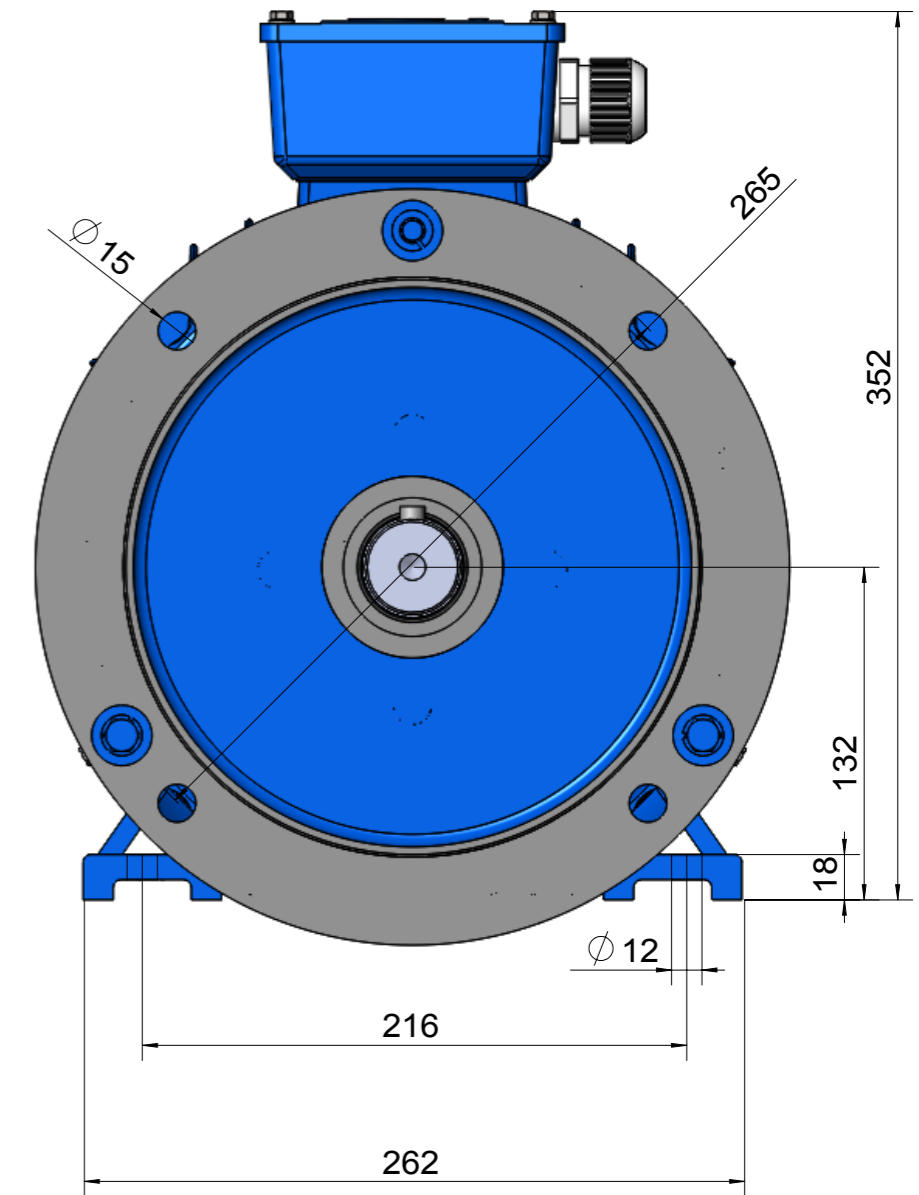
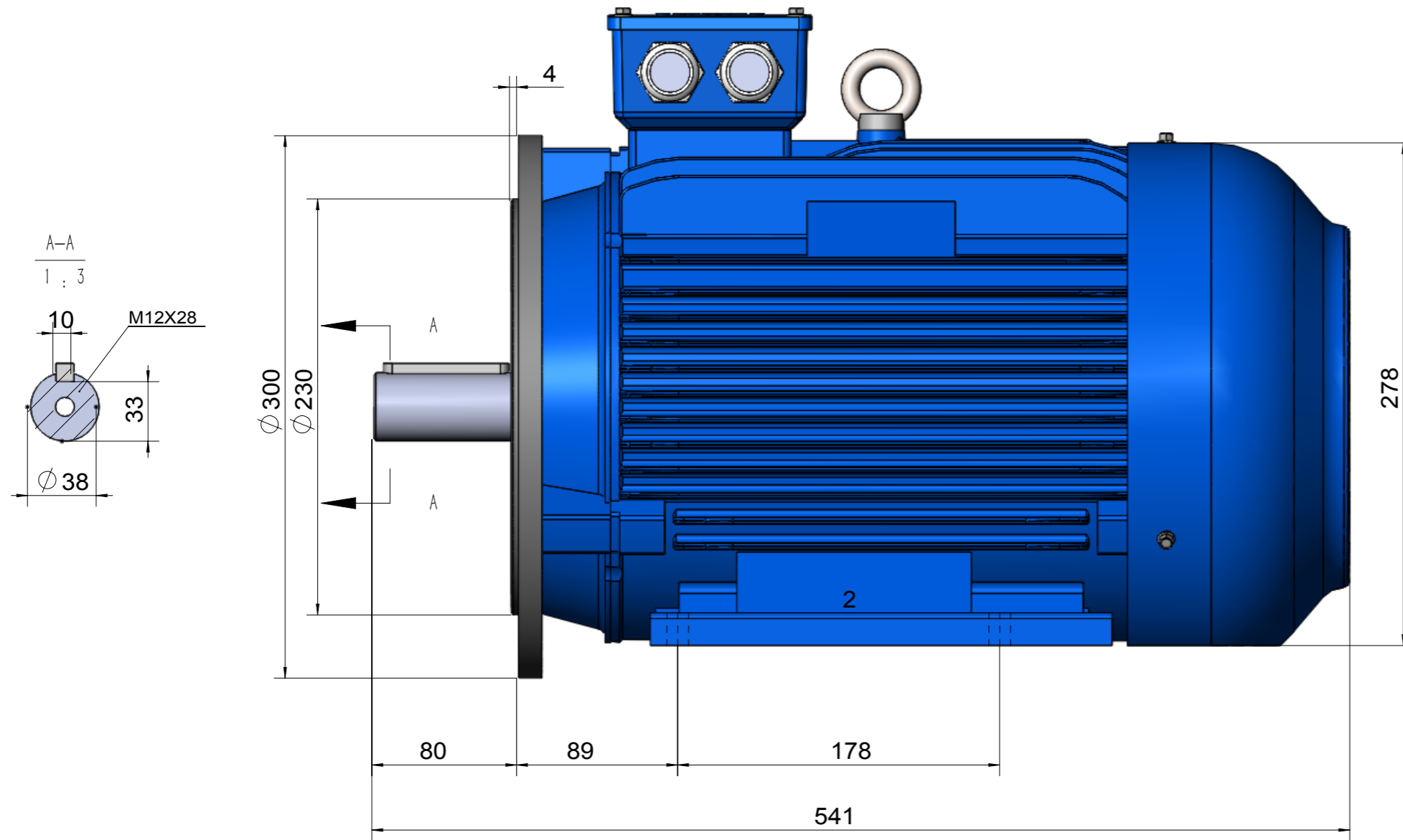

**IE3-132M-B35**  
**Mounting diagram**